



RIGID FRAMEWORK "SPLASHER" SWIMMING POOL INSTRUCTIONS

DANGER

DO NOT DIVE OR JUMP INTO YOUR POOL! ADULT SUPERVISION REQUIRED!
Your pool is approximately 4' deep. It is not designed for diving or jumping.



If you dive or jump into your pool you run the risk of permanent injury or death. Alert all visitors and family of this and point out all warning labels supplied. Watch children at all times.
Pool not designed for diving or jumping!



GENERAL

INSTALLATION OF THIS ABOVE GROUND POOL IS NOT EXTREMELY HARD OR CONFUSING, BUT IT IS A BIG JOB. THE SECRET TO INSTALLING A POOL SO THAT IT WILL GIVE YOU YEARS OF PLEASURE IS TO TAKE THE TIME TO FOLLOW INSTRUCTIONS AND DO THINGS RIGHT THE FIRST TIME. YOUR POOL WARRANTY IS VOID IF THESE INSTRUCTIONS ARE NOT FOLLOWED 100%. READ ALL INSTRUCTIONS INCLUDING ACCESSORIES SUCH AS FILTERS, PUMPS, SKIMMERS, DECKS, ETC. PRIOR TO STARTING. ANY AFTERMARKET OR HOME BUILT DECK, IF ALLOWED, SHOULD BE CONSTRUCTED ACCORDING TO ALL LOCAL BUILDING CODE REQUIREMENTS, INCLUDING LOAD CAPACITY AND FENCING REQUIREMENTS.

BEFORE YOU START, CHECK TO SEE THAT YOU HAVE THE CORRECT NUMBER OF PARTS. USE YOUR PARTS LIST WHICH IS BROKEN DOWN BY CARTON.

THE MANUFACTURER RESERVES THE RIGHT TO REVISE, CHANGE, OR MODIFY CONSTRUCTION OF THEIR POOLS.

NOTE: If a power drill is used during installation, it should be a variable speed drill used on low setting. Torque should not exceed 58 inch pounds. Failure to comply could result in screws stripping out.

313 Regina Avenue • Rahway, New Jersey 07065-4891 USA

Tel: (732) 574-1500 • Fax: (732) 574-1551

www.heritagepools.net • E-mail: info@heritagepools.net

Contract Installations

The manufacturer is in no way affiliated with any professional pool installer. Therefore the manufacturer can assume no responsibility, for errors in installation by the home owner or said professional installer. If you have your pool installed by others, please supervise to be sure they comply with the proper installation techniques shown. Their past experience or short cuts may not cover the latest improvements in our pools. Do not allow any short cuts of any nature.

Local Codes

Local building code may require obtaining a building permit and may have regulations on set backs, barriers, devices and other conditions that must be followed. Any after market or home built deck should be built to the local building code requirements, including load capacity and fencing requirements.

Local electrical code may require obtaining a building permit and may have regulations on setbacks, devices and other conditions that must be followed.

All electrical outlet connections should be a minimum of 5 feet from the outside perimeter of the wall of the pool. From 5-10 feet there should be either a fixed connection (outlet box) or twistlock connection with a GFCI. Connect power cords to a 3-wire grounding-type outlet only.

Severe electrical shock could result if you install your pump or filter on a deck. They could fall into the water, causing severe shock or electrocution. Do not install on a deck or other surface at, above or slightly below the top seat of the pool.

Barrier Requirements

If the distance from the top of the assembled pool is less than 48" vertically from the surrounding grade, a fence or barrier is needed to surround the pool with a minimum height of 48".

A barrier is necessary to provide protection against potential drowning and near drowning and is not a substitute for constant supervision of children. A barrier is a fence, wall, or a combination thereof which completely surrounds the swimming pool and obstructs access to the swimming pool. Barriers must comply with local and national building codes and the US Consumer Product Safety Commission.

These are minimum fencing and barrier requirements. Check your local building codes for other requirements they may request. Optional fencing kits are available, Please contact your local dealer.

If pool covers are used for safety barriers they should comply with ASTM F 1346 "Standard Performance Specification for Safety Covers and Labeling Requirements for All Covers for Swimming Pools, Spas and Hot Tubs."

Special Care

Even though this manufacturer's pools are designed to meet or exceed industry recommended safety factors, special attention must be paid to some installation procedures that the installer performs and controls.

- Levelness- spend the time to assure that the entire pool framework is level within 1". Unlevel pools place extreme pressures on the pool walls
- Wall Seam- this area is where the wall joins together. Damage to any part of this area reduces the safety factors and can result in a weak pool. Use extreme care following instructions.
- Earth Mound- this keeps the liner from creeping out from under the pool wall. Follow instructions to the letter - don't short-cut or substitute materials. Improperly installed pools can rupture, allowing thousands of gallons of water to rush out causing extensive property damage and injury to anyone in its path.
- This manufacturer's pools are not designed to be buried. Outside ground forces can collapse pool wall.
- The pool owner has the sole responsibility for providing adequate lighting for the pool area. It is important that all users must be able to see the shallow depth of the pool, and safety signs at all times.
- You must install a pool ladder(s) for entry and exit from the pool
- All components such as the filtration system, pumps and heater should be positioned as to prevent their being used as a means of access to the pool by young children

Introduction

The installation of an average pool size pool (18' - 27' diameter) will usually require three people to help set it up. Below is an assortment of tools and materials which you will need for preparing the ground, checking the levelness, and setting up the pool.

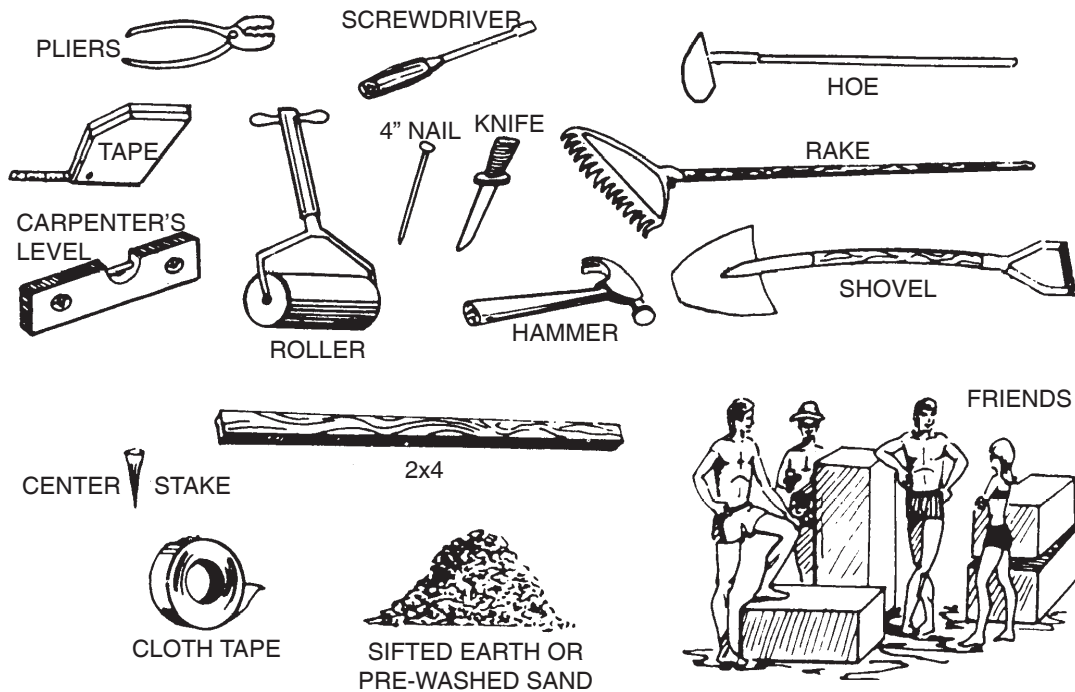

Selecting Pool Location

The selection and preparation of the pool site is your responsibility. The manufacturer can only suggest the proper techniques, indicate the important considerations and emphasize the precautions, and cannot be held responsible for damages to your pool that may result from failure to carefully follow all pool site specifications.

1. The surface on which your pool will stand must be **ABSOLUTELY LEVEL AND SOLID**. This condition should extend several feet beyond the actual pool area all around. The best surface is bare solid earth free from stones, roots, and other sharp objects.
2. Allow plenty of play area around the pool. Fit the location into your landscaping plans.
3. The pool site must be accessible to electrical and water supply and should allow for disposal of great quantities of water when pool is drained.
4. When installing your pool on a **SOLID LEVEL SURFACE**, it is imperative that you protect your pool and liner from chemicals and other foreign matter contained in the surface. Protect your pool and liner by inserting between them and the surface any material that is not made from a tar derivative or contains sharp twigs, etc. We suggest the use of a plastic ground shield to be used between the surface and the pool liner. Do not install your pool on peat moss, tar paper, gravel or chemically treated soil. Any or all of these surfaces can ruin your pool and liner and will void your liner warranty.
5. Do not set up your pool under trees or under overhead wires.
6. **DO NOT** set up your pool near any existing structure such as your house garage, etc., as this condition will induce diving or jumping into your pool which could result in permanent injury or death.
7. Do not set up your pool on or near any septic system or underground utilities.
8. Choose your pool location convenient for:
 - a. Connecting electrical wires of your accessories (filter, heater, lights) to your electrical outlets conforming to electrical codes.
 - b. Draining large amounts of water.

1

PREPARING THE GROUND

Your pool must be installed on a solid level surface. Drive a stake into the ground at the center of your pool location. With the use of the leveling device shown and a shovel start leveling the ground, removing all grass and sharp objects such as sticks and stones.

Level area to the lowest spot within the clearance radius. DO NOT FILL IN LOW SPOTS. Give special attention to the outer part of the circle as this is where the bottom track and pool wall will rest and must be absolutely level.

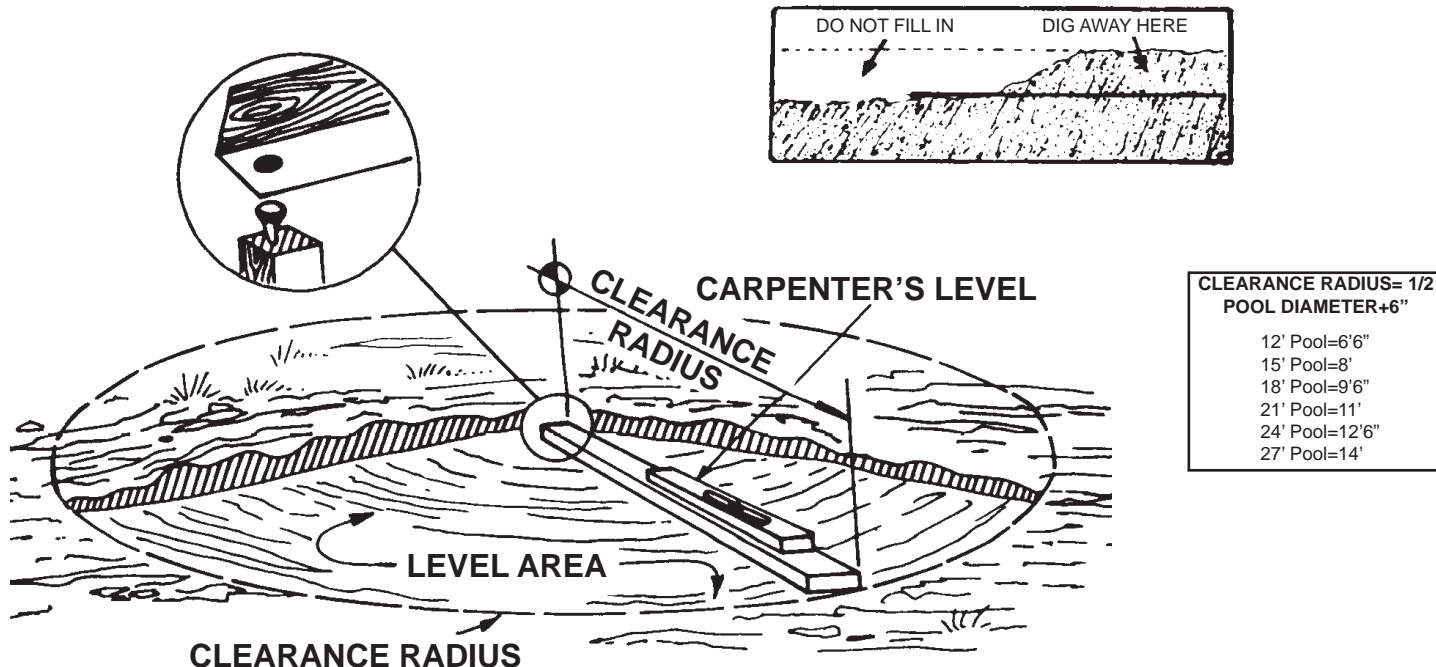

The assembled pool must have a vertical distance of 3' from the top of the pool to the adjoining grade and the adjoining grade must remain level for a distance of 4' away from the pool. Refer to the drawing at right.

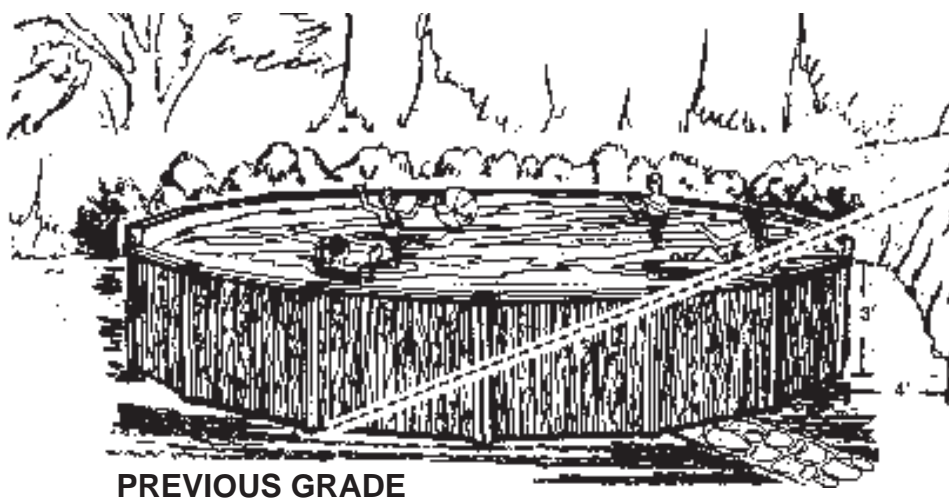

WARNING - LEVELING THE GROUND

THIS IS THE MOST IMPORTANT PART OF YOUR PREPARATION OF POOL SITE. YOU MUST GIVE CAREFUL ATTENTION TO THIS PHASE. REMEMBER --- YOUR POOL MUST BE INSTALLED ON SOLID LEVEL SURFACE.

2

BOTTOM RAIL

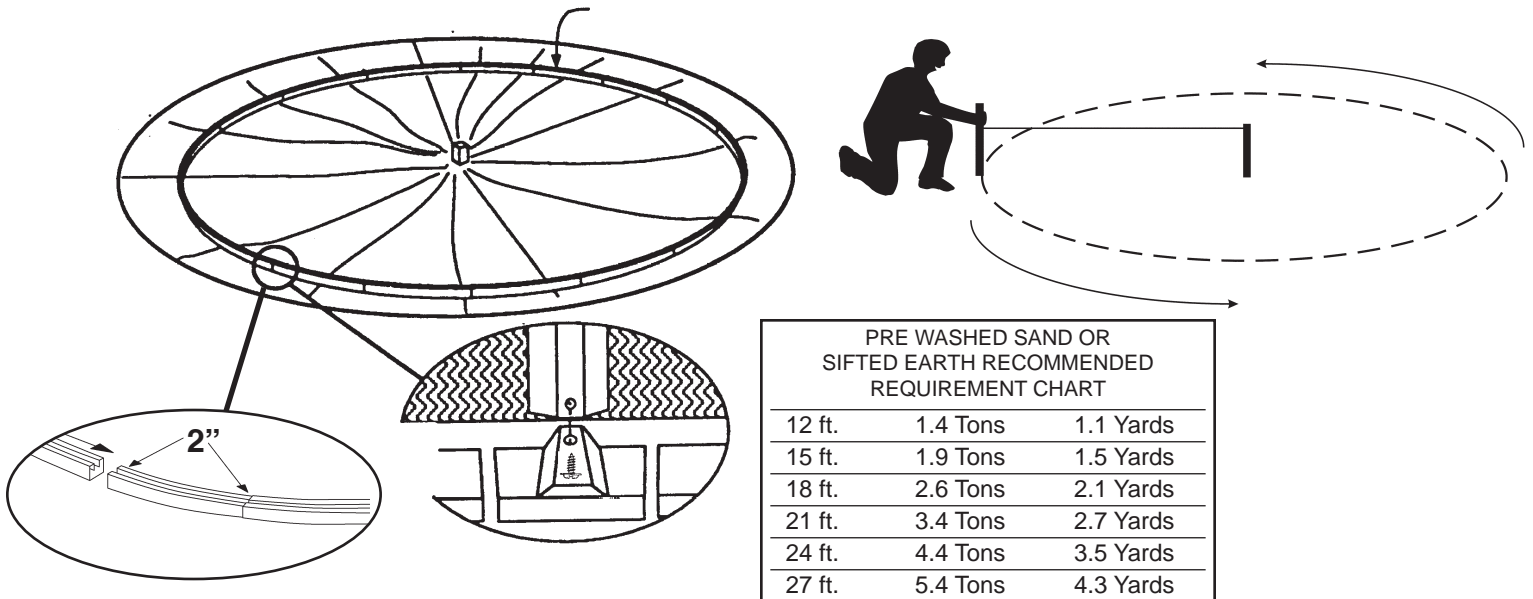

Ground Shield and Wall Guard are optional.

Spread a ground shield or plastic sheeting over prepared ground (not included). Ground Shield and Wall Guard are available from your local pool supply dealer or polyethylene sheeting can be purchased from a local hardware supply. This will protect your pool liner and metal parts against chemical reactions from the ground soil.

Mark out pool radius (1/2 pool diameter) using the center stake as reference. The slots in the bottom track must face upward.

On pool models with the 1" bottom rail and 1 3/4" verticals:

Form a circle by sliding the end of the bottom track into the rail/vertical connector leaving 1/4" gap between each rail, in the center of the connector. Continue in this manner all the way around pool, until the circle is complete.

On pool models with the 5/8" and 9/16" interlocking rails:

Form a circle by inserting the 9/16" rail into the 5/8" rail approximately 2". Continue in this manner all the way around the pool until the circle is complete, alternating a 9/16" rail then a 5/8" rail.

Check that the bottom framework of your pool is perfectly round by measuring the distance between the central stake and the rails at various points. Bring the required amount of sifted earth or prewashed sand into the pool area at this time. Refer to chart above for the required amount. On the 36" and 42" models the actual diameter of the 12 ft round pool is 11' 7 1/2".

3 INSERT WALL INTO BOTTOM RAIL

Remove wall from carton.
Note the UP arrow on wall.

Determine starting point as the filter inlet and outlet holes are at the beginning of the wall. Starting at the center of a bottom plate insert the bottom edge of wall into the groove on the bottom rail. Make sure that the cutouts for filter inlet and outlet are on the top portion of the wall and will not be hidden behind a vertical. If the wall ends do not meet, adjust the bottom rail in or out of the bottom plates. The spacing in all bottom plates should be equal.

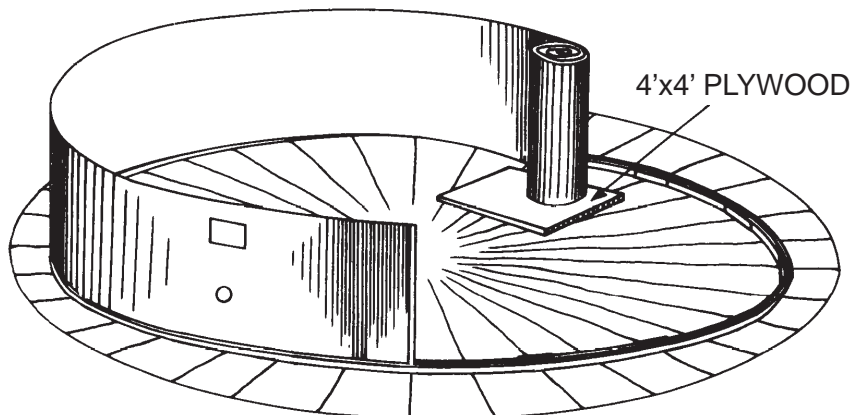

4

CLOSING THE WALL

DANGER

YOU MUST ASSEMBLE THE POOL WALL AS PER INSTRUCTIONS

USE ALL BOLTS, LOCK WASHERS, AND NUTS TO CLOSE POOL WALL

DO NOT LEAVE ANY OPEN HOLES

TIGHTEN SECURELY USING ADJUSTABLE OR OPEN END WRENCH. DO NOT USE SOCKET WRENCH TO TIGHTEN BOLTS. DO NOT OVERTIGHTEN BOLTS

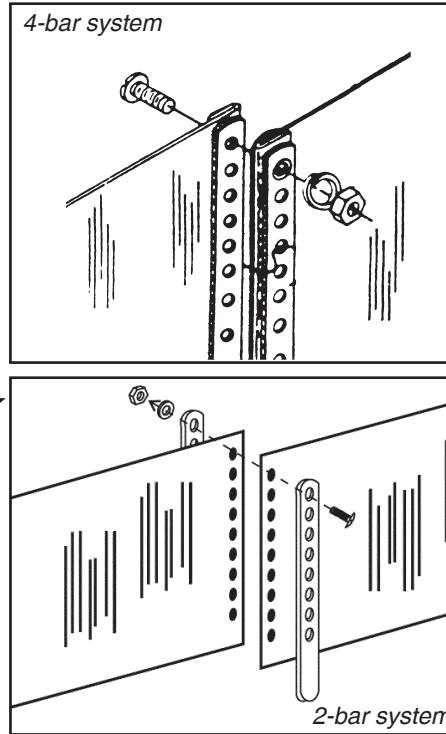
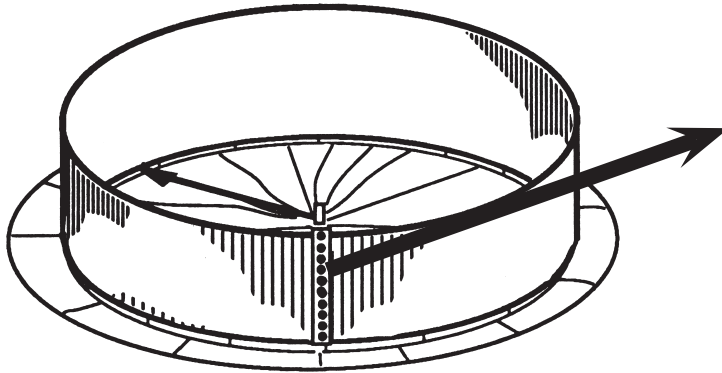

Insert the 1/4" - 20x3/4" truss head screws from inside the pool through the preattached inside closure bar, through inside and outside wall ends and through outside closure bar. The 1/4" lockwashers and 1/4" hex nuts are secured to the screws on the outside of the wall.

All the holes must match and be secured together with the screws and nuts. This is one of the most important structural assembly aspects you will perform.

Be absolutely sure you have one closure bar inside of pool (in between liner and pool wall) and one outside (exposed on outer pool wall), sandwiching together the wall ends.

Manufacturer can not assume the responsibility of the performance of this product if the instructions of closing the wall are not followed exactly.

5

PROTECT YOUR LINER

Once the wall is closed and screws and nuts are tightened securely, cover the screw heads on the inside of the pool with a cloth tape all the way from top to bottom of wall. If the cutouts for filter inlet and outlet are not used, tape over the prescored areas on the inside of the pool wall.

Cloth tape or duct tape is available through your local pool dealer or hardware store.

WALL SEAM

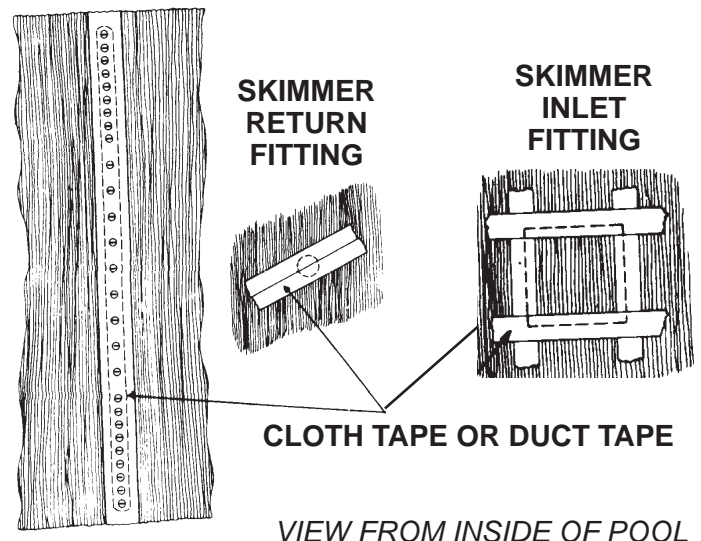

6 RECHECKING YOUR WORK

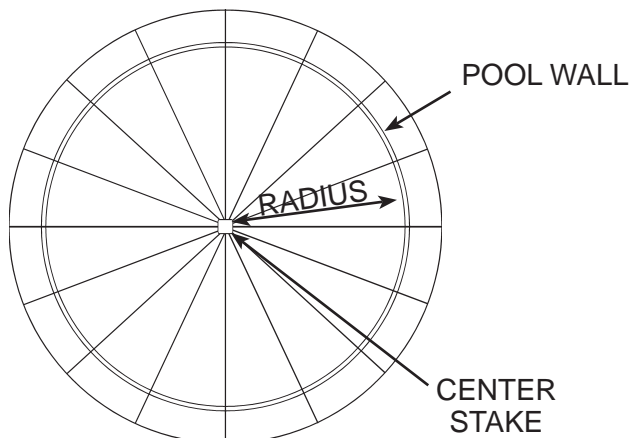

VIEWED FROM ABOVE

Using the center stake make sure your pool is completely in true round by measuring from the center of the stake to inside of pool wall in all directions, making sure these measurements are equal.

Remove center stake from pool area after measurements and adjustments, if necessary, are made.

7 BUILDING THE EARTH MOUND

Wall guard is optional.

Tape wall guard (plastic sheeting) to pool wall 12" up from ground and smooth out on ground 12" from wall. This will protect your pool's metal parts from chemical reactions with the soil used in the earth mound.

Build earth mound on top of wall guard using screened damp earth or pre-washed sand. Shape and compact earth mound to run 8" up from ground and 8" away from the wall. Do not use any material that will compress under pressure for the earth mound is an important part of the pool installation. It prevents the wall from lifting up and from the liner sneaking underneath the pool wall.

Spread the remaining sand equally across the bottom of the pool. This will give you a 2" to 3" sand base.

Manufacturer cannot assume responsibility of the performance of this product if the earth mound is omitted or not properly installed.

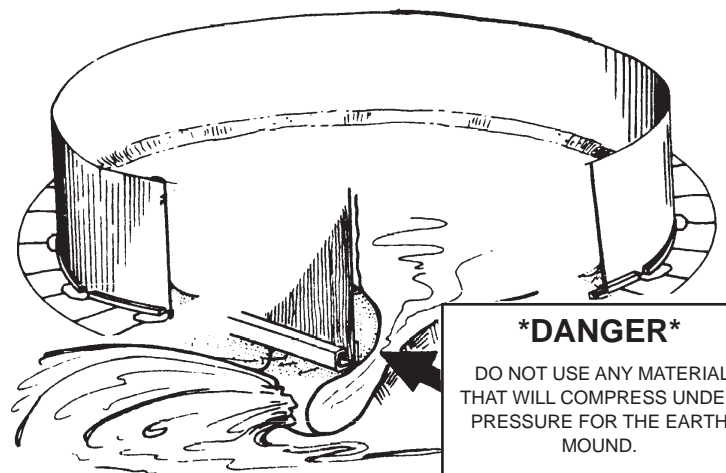
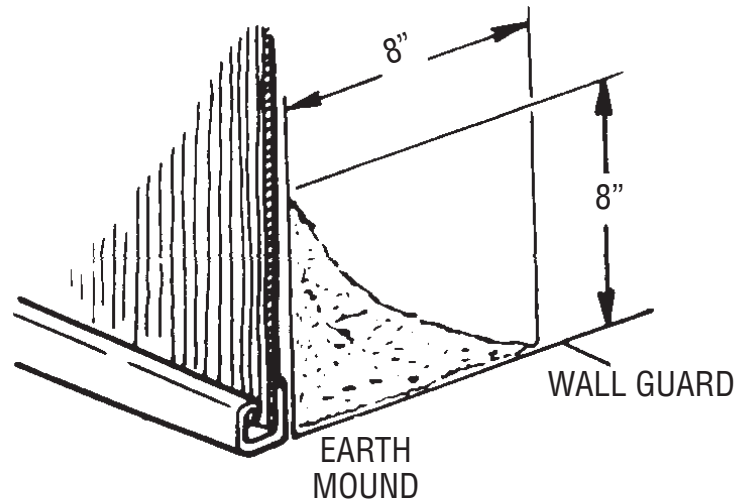

DANGER

DO NOT USE ANY MATERIAL THAT WILL COMPRESS UNDER PRESSURE FOR THE EARTH MOUND.

SEE INSTRUCTIONS TO LEFT.

8 THRU-THE-WALL SKIMMER

If the through wall filter inlet and outlet holes are to be used, remove metal cutouts by breaking perforations using a knife and hammer as shown. Refer to skimmer manufacturer's instructions for remainder of skimmer assembly. Make sure skimmer does not leak as this will corrode the pool wall and cause a split in the wall that is not covered under the pool warranty.

It is recommended to coat the exposed metal on both sides with a clear lacquer or nail polish to help resist rust and corrosion.

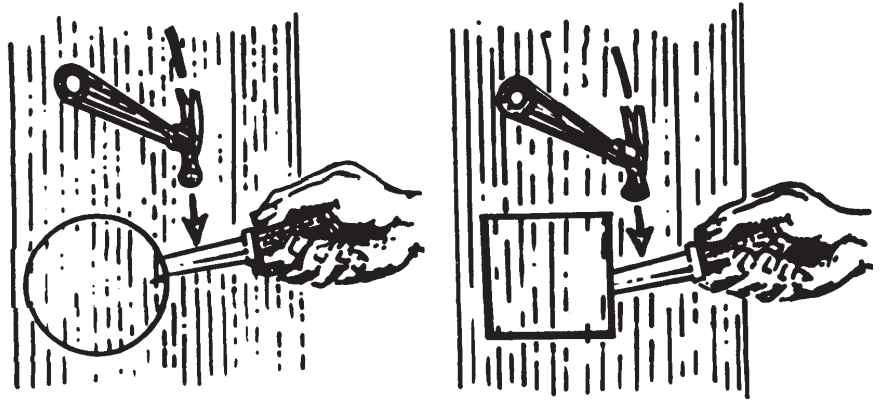

9 PORTHOLE INSTALLATION

Pool models not equipped with a porthole, proceed to step #10

The Porthole assembly must be placed into the pool wall before installing the liner.

As illustrated, place the Porthole Lens inside the pool and position it so that its four Snap Locks project through the round hole in the pool wall.

Position the Porthole Trim Ring on the outside of the pool so that its four Notches align with the four Snap Locks projecting from the Porthole Lens. Snap the Trim Ring onto the Porthole Lens, making sure that the four Snap Locks of the Lens lock securely into the four Notches of the Trim Ring.

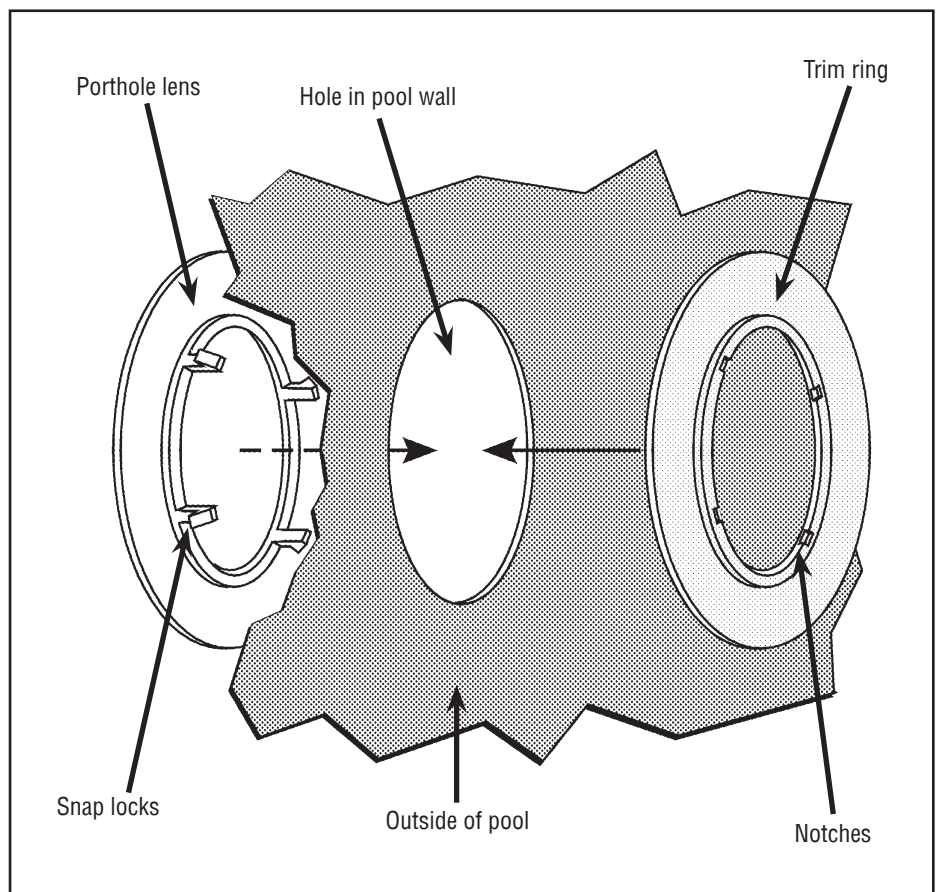

CAUTION

YOUR POOL IS DESIGNED TO PROVIDE AN AMPLE SAFETY MARGIN WHEN IT STANDS ON LEVEL GROUND. FOR THIS PURPOSE A SLOPE IN EXCESS OF 2 INCHES IN ANY DIRECTION WALL TO WALL IS CONSIDERED OFF LEVEL. YOUR POOL WARRANTY ONLY APPLIES TO POOLS INSTALLED ON LEVEL GROUND AS DEFINED ABOVE.

ONCE YOU HAVE STARTED TO FILL THE POOL, DO NOT TRY TO PULL THE LINER FORCEFULLY. THE WEIGHT OF EVEN ONE INCH OF WATER WILL MAKE IT IMPOSSIBLE TO MOVE THE LINER WITHOUT DAMAGING IT.

Spread out liner at the bottom of the pool. Excess material at the seams should be face down.

The bottom seam should lie well up on the earth mound. Drape liner over the wall so that it hangs evenly around the outside of the pool. Make sure enough material is on the inside so the liner lies flat on the earth mound. Secure liner to wall using plastic edging.

Excess material on side of liner should be distributed evenly around the entire pool. Excess material over hanging the wall should be double folded as illustrated and should **not** be cut off.

Wrinkling of liner may be evident. This in no manner reduces any structural strength. You can now start filling the pool with water.

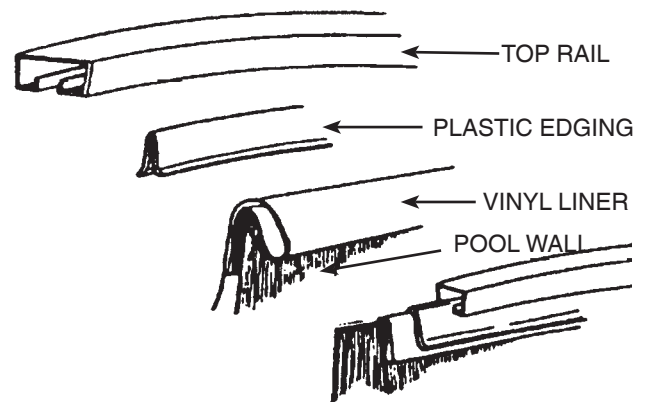
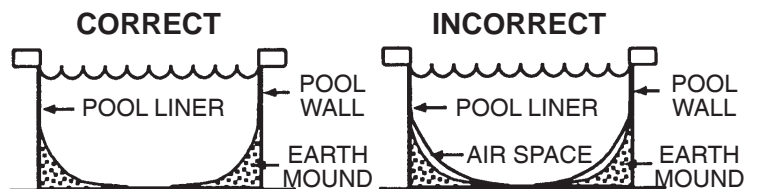
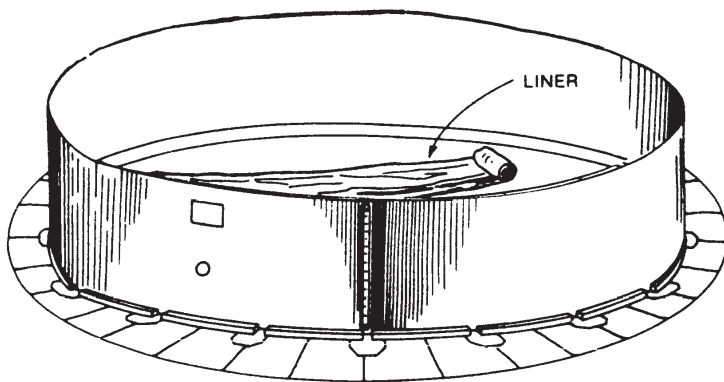

OUTSIDE VIEW OF POOL WALL

On pool models equipped with a porthole

Align the clear section of the liner with the porthole cutout in the pool wall. The clear section in the liner is oversized to allow for easier alignment.

It is important that after the alignment, the liner seam still lays flat on the Earth Mound and is not suspended in the air. If the liner is suspended at all, simply build up the Earth Mound more in that location.

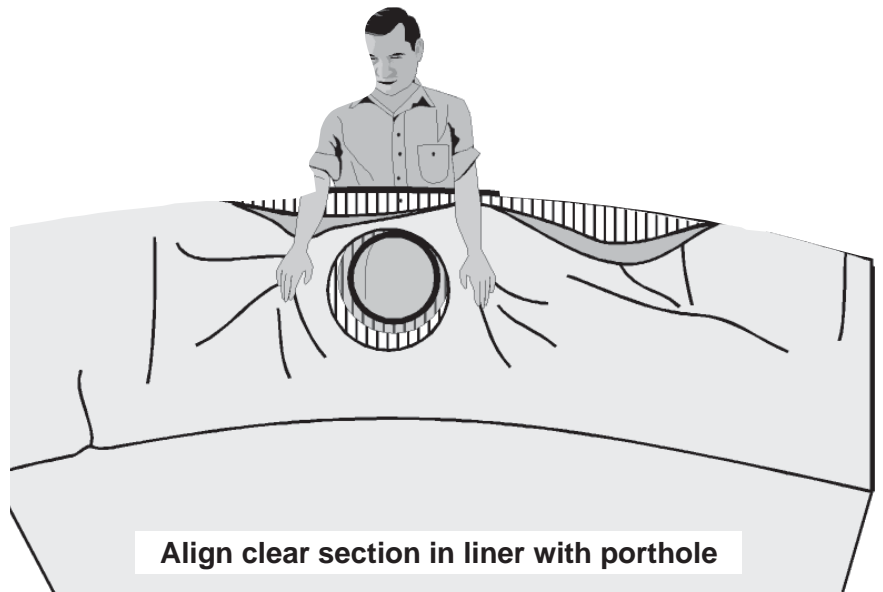

11

VERTICALS

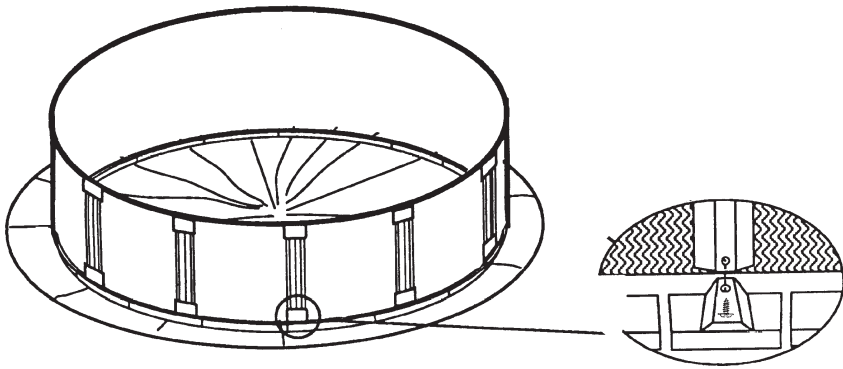

Attach verticals to bottom plates on the outside of pool using the No. 10 x 1/2" Sheet Metal Screws.

If your pool is equipped with feature tape, it is best to apply it to the verticals at this time.

12

INSTALL TOP RAILS

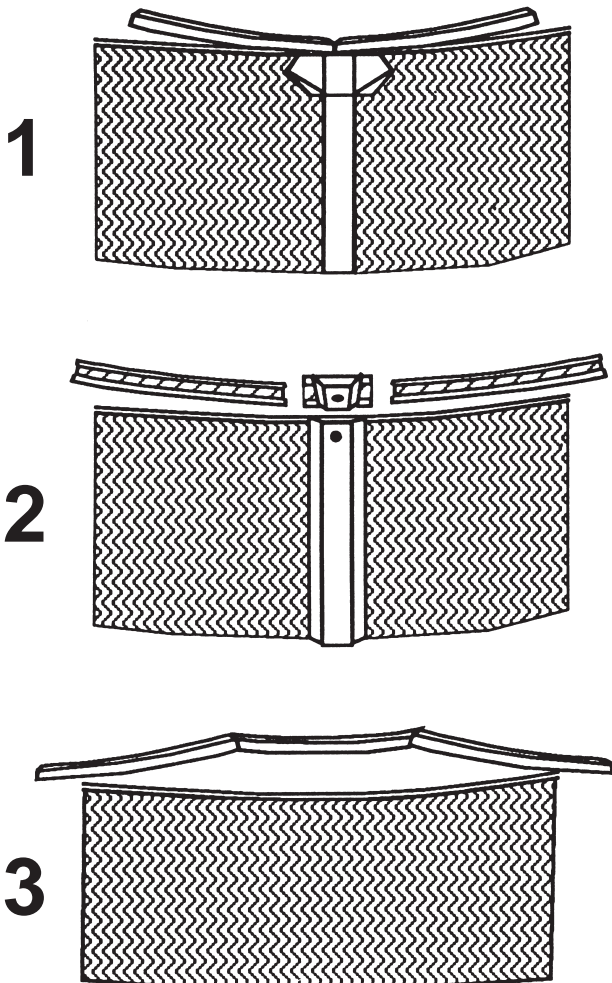

On pool models with the 1" top rails and 1³/₄" verticals (A):

Slide the ends of two top tracks into a rail/vertical connector in the same manner as you have done on the bottom track. Align the connector directly over a vertical and push the tracks and connector down over the wall and edging, leaving the two exposed ends in the air. Fasten the connector to the vertical using the 1/2" sheet metal screw. Slide another connector and a track into the track already installed on the pool and press connector and track down onto the wall and edging, again on top of a vertical and leaving one end exposed and in the air. Fasten the connector to the vertical using the #10 x 1/2" sheet metal screw. Continue in this manner all the way around the pool.

On pool models with the 5/8" and 9/16" interlocking rails (B):

Simply slide a 9/16" rail into a 5/8" rail approximately 2" as done on the bottom track in step# 2. Press assembly down over the wall and edging, leaving the 2 exposed ends in the air (fig. 1). Continue assembly all the way around the pool, pressing the rail down over the wall as you had done on the bottom track, edging as you go.

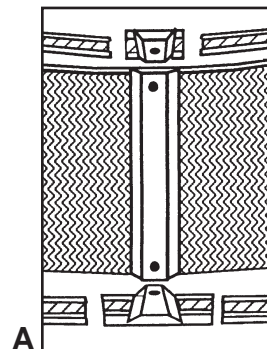

CONSTRUCTION CLOSE-UPS

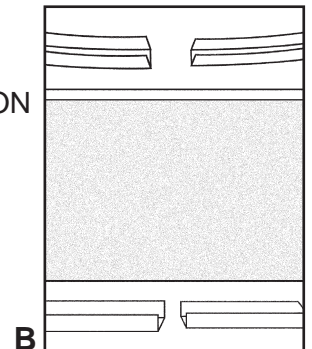

Four (4) danger labels have been provided for your safety. Apply these labels to the pool where they are easily visible to all persons using the pool. To do this, simply peel the backing off the label to expose the self stick back and firmly press to conspicuous and plainly visible surface on the pool.

DO NOT REMOVE THE DANGER LABELS UNDER ANY CIRCUMSTANCES.

The manufacturer has provided warning signs to prevent diving and/or jumping into your pool. Alert all pool users to these signs.

Should you need additional labels for any reason, the manufacturer will supply these labels to you at your request. Simply order the desired label by part number either from your local dealer or direct from the manufacturer.

Consumer Awareness Booklets: The following books are available through the National Pool & Spa Institute: "The Sensible Way To Enjoy Your Pool"...published by the NSPI, October 1983 (revised September 1986), "Children Aren't Waterproof"...published by the NSPI, "Pool & Spa Emergency Procedures For Infants And Children"...published by the NSPI.

Contact:

APSP

2111 Eisenhower Avenue, Alexandria, Virginia 22314

(703) 838-0083



#490021

TREATING THE WATER

WARNING: The information contained in the following sections about Water Treatment and Filtering are generalities. If you acquire any of these materials, we recommend that you follow the instructions which accompany the given product closely.

In order to keep the pool water clean and clear, you must use a disinfecting agent. Its role is to kill off any micro-organism and bacteria contained in the water and to prevent algae growth. Disinfection involves two main factors: the water's acidity (pH) and its chlorine content.

The pH value indicates whether a given body of water is acid or alkaline and to what degree.

The water in a swimming pool must have a pH value ranging between 7.2 and 7.6. Beyond this level, the action of chlorine is considerably inhibited and the water can become irritating. If the pH value is below 7.2 the water is aggressive and can be the cause of corrosion of the metal parts of pool appliances.

CHLORINE CONTENT

This is measured in milligram-liters (mg/l) of active chlorine. This value must be situated between 0.4 and 1 mg/l. The water must be tested for pH and chlorine values by colorimetric analysis, using an analysis kit. We strongly recommend that you replace the kit's reagents once a year. Observe the instructions provided with the kit.

I - PUTTING THE POOL INTO SERVICE

When reopening the pool or refilling it with water, the following operations should be performed:

1-pH

Check the pH value, which should be situated between 7.2 and 7.6. Use the analysis kit. If the pH value found is higher than 7.6, use "pH MOINS" (pH decriaser);

If the pH value found is lower than 7.2, use "pH PLUS" (pH increaser).

Comply with the dosages indicated on the package.

2-Chlorine

Check the active chlorine value, which must be at least 0.4mg/l.

If the value found is lower than this, use chlore rapide (rapid action chlorine) in granu-

lated or tablet form in order to rapidly rebuild the minimum active chlorine level.

For normal operating, place the 200g or 600g chlore lent (slow action chlorine) chlorine cakes in the skimmer (200g for 25 m³ water). The slow distribution of this chlorine will keep the chlorine values of your pool stable for approximately 8 to 10 days.

WARNING: It is very important that chlorine products be placed exclusively in the skimmer.

3-Stabilizing agent

Sun rays and warm water temperatures decompose chlorine, largely impairing its disinfecting capacity and leading to increased chlorine requirements. In order to eliminate this problem, when filling the pool, use the stabilisant stabilizing agent.

This operation need not be renewed as long as the pool is not drained. Please see the instructions provided with the technical description of the product.

Please note that addition of too much stabilizing agent will have a chlorine-inhibiting effect. In this case, it suffices to eliminate 2 to 3% of the water in the pool every week, preferably during cleaning operations.

4-Water-softening agent

If using hard water (containing lime), initial treatment is very important. In order to prevent lime deposits in the pool or in the filter, use a water-softening or anti-liming product, following the instructions on the package.

II - MAINTENANCE

When all the above operations have been successfully performed (pH, Chlorine, stabilizing agent and anti-liming agent), it is importante to ensure proper maintenance:

1- Once a week, control pH and chlorine levels.

The pH value is generally quite stable, but it can be modified by adding water to the pool and by the use of organic chlorine (e.g. Javel water or Clorox), which often raises the water pH level and decomposes rapidly.

2-Check chlorine level.

If it has dropped below 0.4mg/l, use chlore rapide (rapid action chlorine).

3-Check

(slow action chlorine; 200g or 600g) in the skimmer. Do not wait for them to dissolve entirely before adding the new ones.

III - ANTI-ALGATE TRETMENT

1-Preventive treatment:

At the dosage prescribed above, chlorine also acts as an algicide. Stormy weather, frequent use of the pool, faulty filtering are factors which can increase the rate of algae formation, resulting in slippery, slightly greenish walls. In this case, do not hesitate to apply a high chlorine dosage and leave the filter on around the clock.

2-High-dosage algicide:

If in spite of this measure the algae do not disappear, use a very active algicide.

IV - FLOCCULATION

Certain very fine organic particles may not be sufficiently filtered by sand filter action. The use of a flocculating agent will enhance the efficiency of filtering, thus eliminating all suspended particles in pool water.

Start by putting the flocculating agent into the filter. If it turns out that this is insufficient, perform flocculation directly in the pool itself. Observe the instructions on the package.

V - WINTER CARE

1. If thru wall skimmer inlet and outlets are used, the skimmer must be blocked off with a block off plate to prevent any water from laying in the skimmer. The return fitting must also be blocked off by using a plug on the inside of the pool. It is very important that the return fitting not protrude into the pool and that water is not allowed to flow into the skimmer. If this is not followed, when the ice in your pool forms it will grab onto your skimmer and return fittings, and if the ice should shift it will rip your wall at these locations.

2. A properly sized ice compensator (pool pillow) must be secured in the pool water to relieve the ice pressure that can exert severe pressure on the pool wall.

3. Proper chemicals must be used in order to prevent algae growth throughout the winter. A strong concentration of chlorine and an algaecide will help.

4. A cover must be used to keep out dirt and debris from the pool. It is important when securing the cover that enough slack is used so that it rests on the top of the water so that the pressure is not on the pool frame. A build up of snow on the top of the cover should be removed.

While the pool is winterized it is important that it remain undisturbed throughout the winter months.